

### THE PUMPMATIC™ RANGE

A BELOW GROUND PUMP SYSTEM DESIGNED AND ASSEMBLED TO SUIT YOUR REQUIREMENTS.

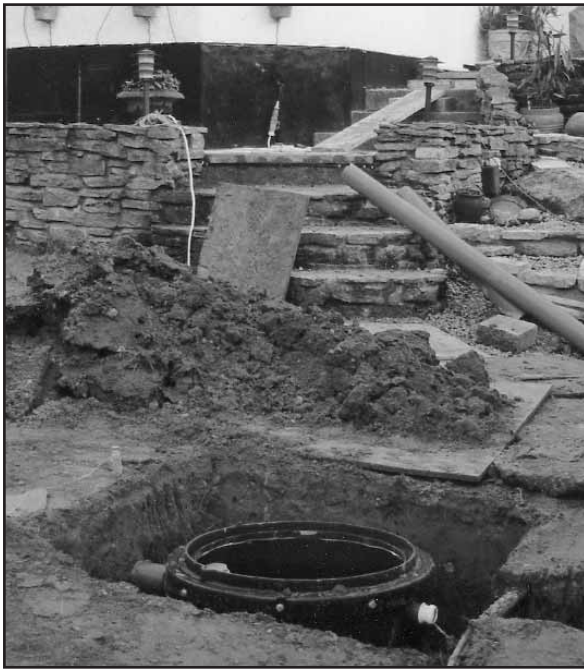

The various versions of the PUMPMATIC range shown here are **EXAMPLES ONLY**. There are dozens of pumps which can be used in each tank (depending on application).

#### *The System would comprise of:-*

- **Pump Chamber** - Sized according to duty, holding requirements, building regulations, etc.
- **Pumps** - Single or Twin operation selected for duty, type of waste, distance and head.
- **Control Panel, Float Switches or probes & Alarms** - depending on requirements.
- **Access Cover** - Pedestrian/Vehicle weight or Double Sealed/lockable

#### Questions we might ask to get the right system for your application:-

- Is the application Domestic or Commercial?
- What will the system have to cope with? (whole property, annex, etc.)
- How many sinks, toilets, wash basins, washing machines, etc.
- Head and horizontal distance required to be pumped to main drains.
- Power supply available 240v or 3 Phase.



### PUMPMATIC 75/750 Packaged Sewage Pumping System (single pump)

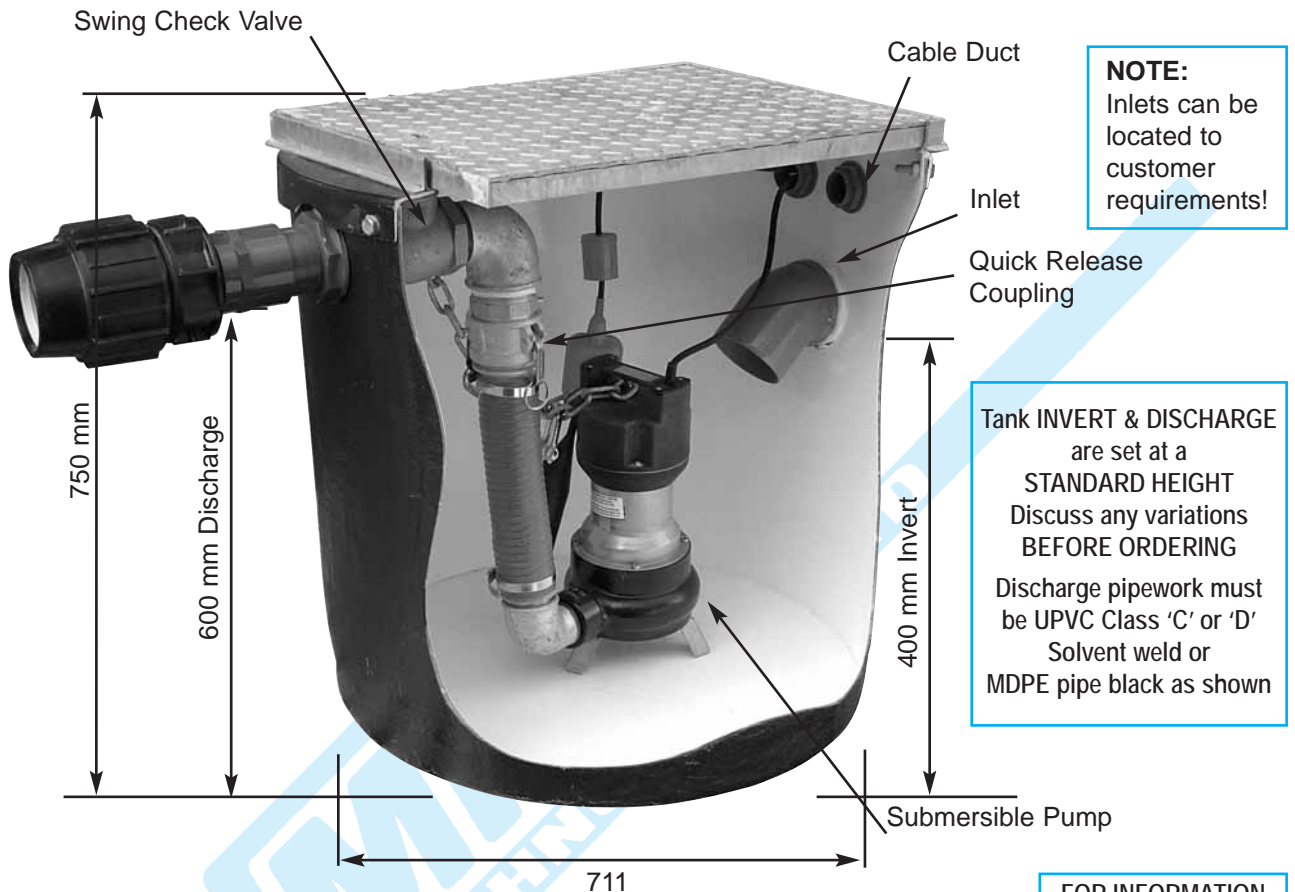

**NOTE:**  
Inlets can be located to customer requirements!

Tank INVERT & DISCHARGE are set at a STANDARD HEIGHT  
Discuss any variations BEFORE ORDERING  
Discharge pipework must be UPVC Class 'C' or 'D'  
Solvent weld or MDPE pipe black as shown

FOR INFORMATION ONLY  
PUMP MAY DIFFER FROM ONE ILLUSTRATED

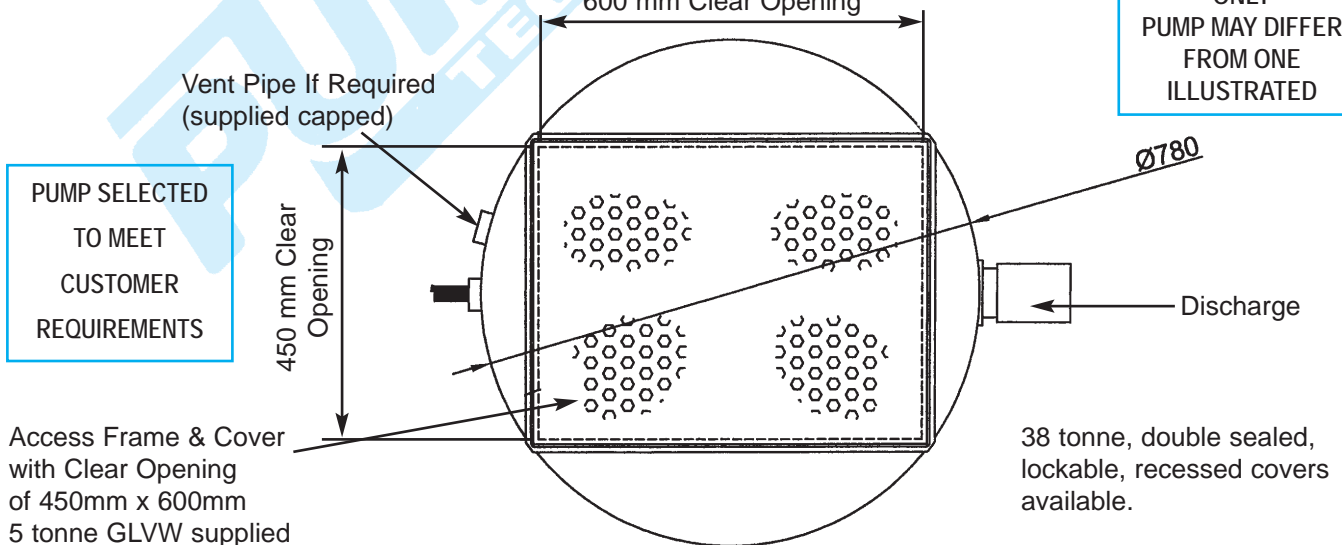

### PUMPMATIC 100 Packaged Sewage Pumping System

Access Frame & Cover with Clear Opening of 450mm x 600mm  
5 tonne GLVW

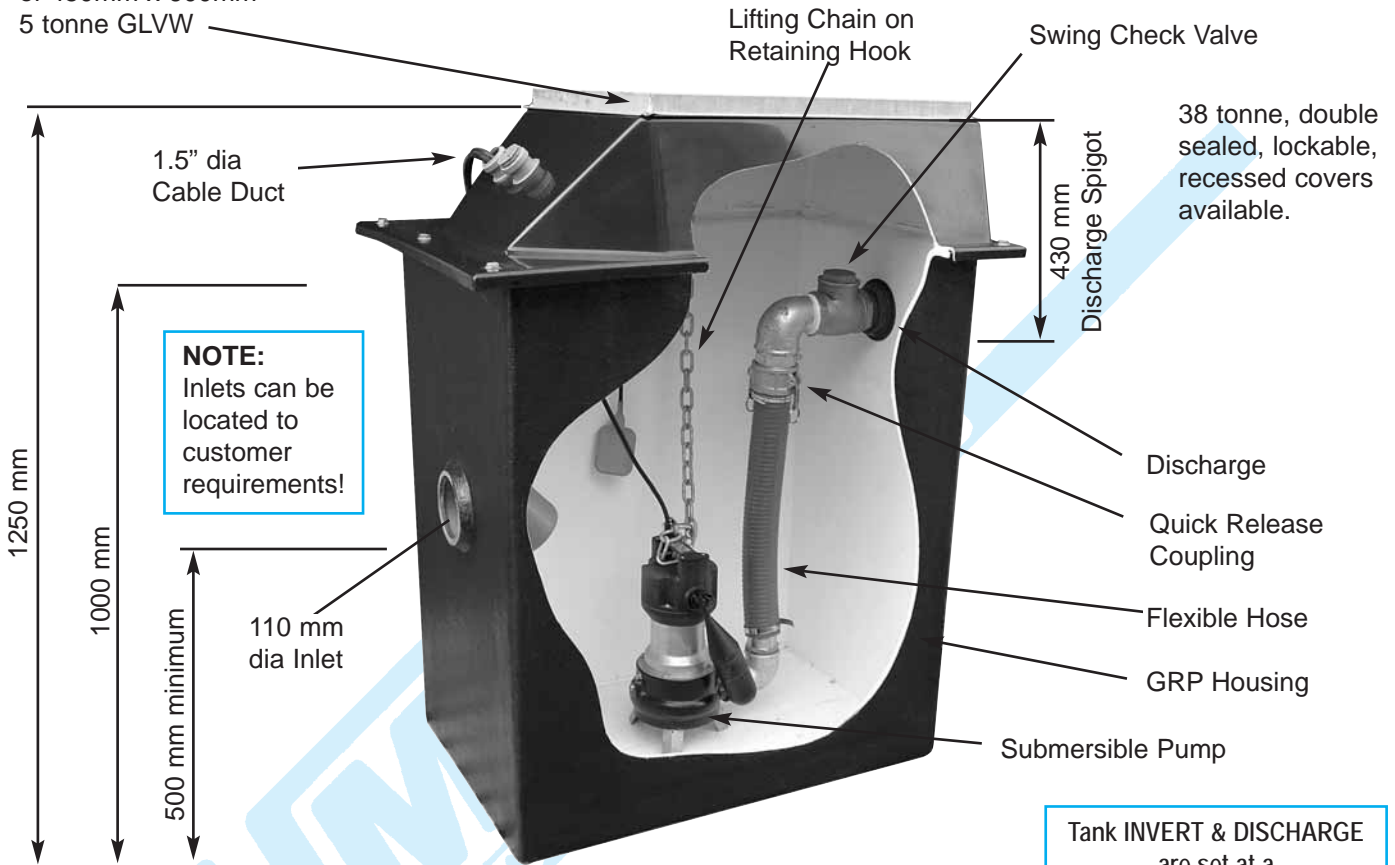

FOR INFORMATION ONLY  
PUMP MAY DIFFER FROM ONE ILLUSTRATED

Extra Connection fitted for Vent Pipe

PUMP SELECTED TO MEET CUSTOMER REQUIREMENTS

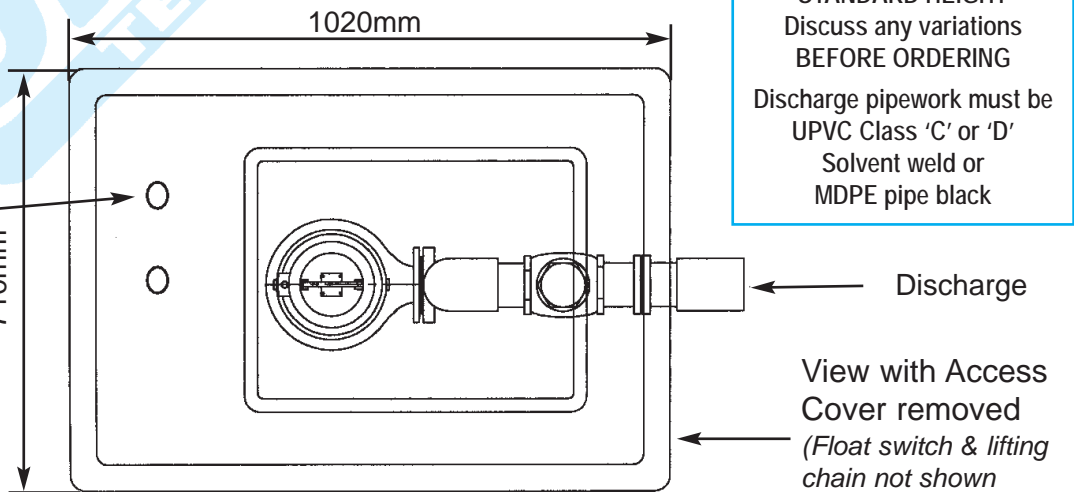

Due to a policy of continuous product improvement we reserve the right to alter specifications without notice.

56 Youngs Industrial Estate, Aldermaston, Berks. RG7 4PW  
Tel: 01189 821555 Fax: 01189 821666  
E-mail: support@pumptechnology.co.uk  
Web Site: www.pumptechnology.co.uk

### PUMPMATIC 125 Packaged Sewage Pumping System

PUMP SELECTED  
TO MEET  
CUSTOMER  
REQUIREMENTS

#### SECTION A-A

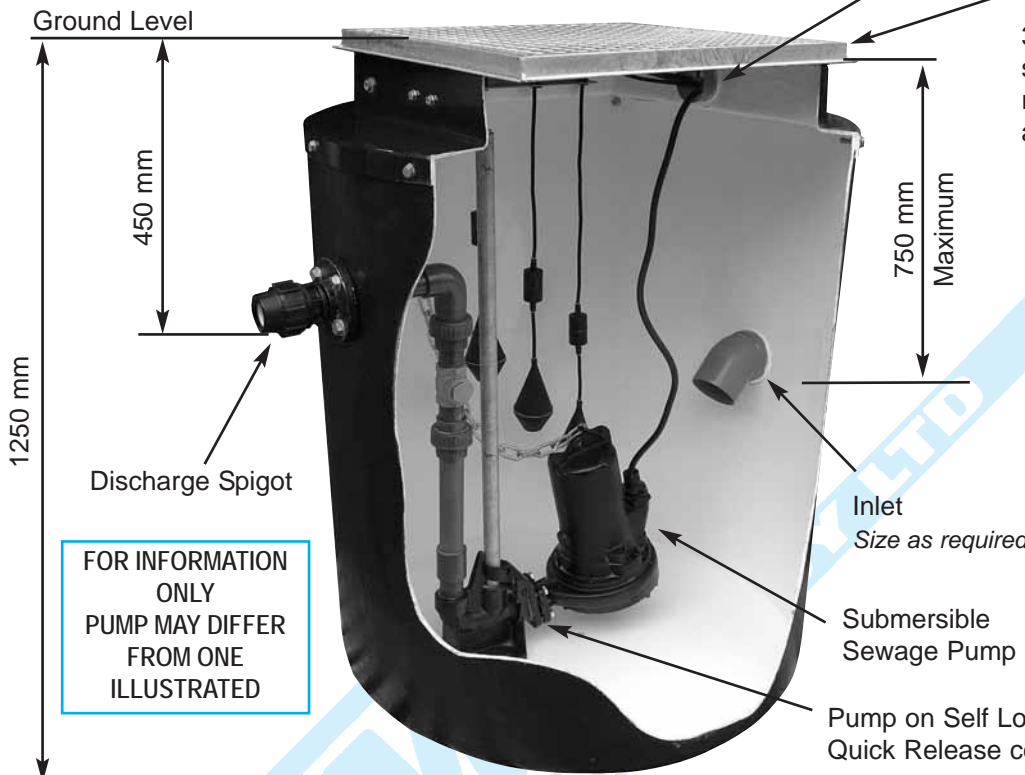

Access Frame & Cover with Clear Opening of 600 x 600 5 Tonne GLVV

38 tonne, double sealed, lockable, recessed covers available.

Tank INVERT & DISCHARGE are set at a STANDARD HEIGHT Discuss any variations BEFORE ORDERING Discharge pipework must be UPVC Class 'C' or 'D' Solvent weld or MDPE pipe black as shown

FOR INFORMATION ONLY PUMP MAY DIFFER FROM ONE ILLUSTRATED

**NOTE:** Inlets can be located to customer requirements!

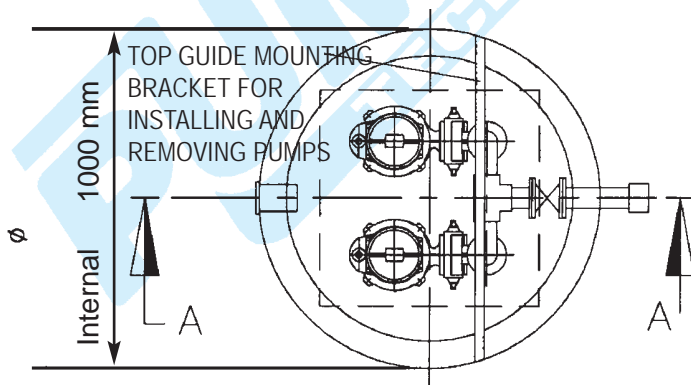

SECTIONAL PLAN OF GRP TANK

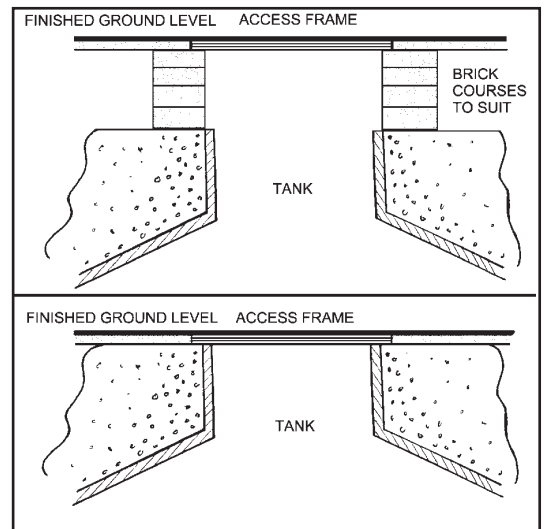

Due to a policy of continuous product improvement we reserve the right to alter specifications without notice.

56 Youngs Industrial Estate, Aldermaston, Berks. RG7 4PW  
Tel: 01189 821555 Fax: 01189 821666  
E-mail: support@pumptechnology.co.uk  
Web Site: www.pumptechnology.co.uk

### PUMPMATIC 200 Packaged Sewage Pumping System

PUMP SELECTED  
TO MEET  
CUSTOMER  
REQUIREMENTS

#### SECTION A-A

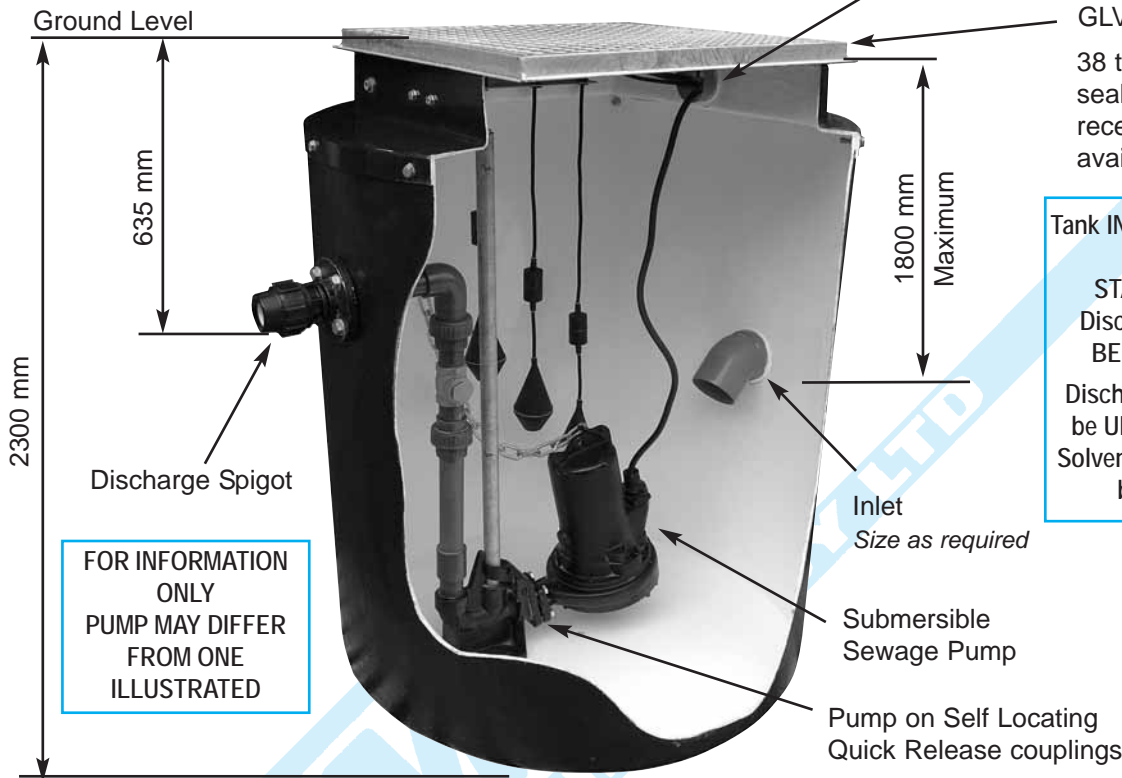

Access Frame & Cover with Clear Opening of 600 x 600 5 Tonne GLVW

38 tonne, double sealed, lockable, recessed covers available.

Tank INVERT & DISCHARGE are set at a STANDARD HEIGHT Discuss any variations BEFORE ORDERING Discharge pipework must be UPVC Class 'C' or 'D' Solvent weld or MDPE pipe black as shown

FOR INFORMATION ONLY PUMP MAY DIFFER FROM ONE ILLUSTRATED

**NOTE:** Inlets can be located to customer requirements!

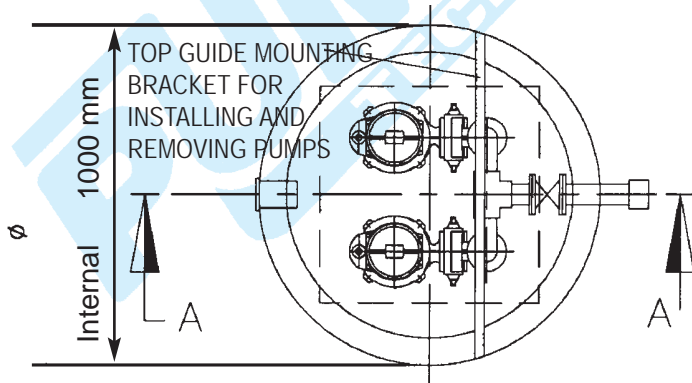

SECTIONAL PLAN OF GRP TANK

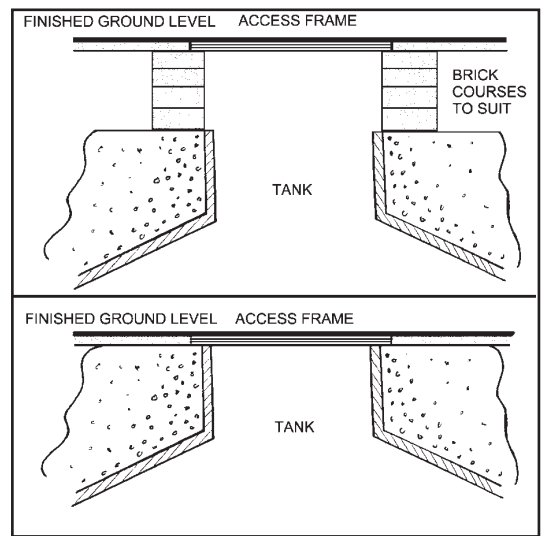

Due to a policy of continuous product improvement we reserve the right to alter specifications without notice.

56 Youngs Industrial Estate, Aldermaston, Berks. RG7 4PW  
Tel: 01189 821555 Fax: 01189 821666  
E-mail: support@pumptechnology.co.uk  
Web Site: www.pumptechnology.co.uk

## PUMPMATIC 300 Packaged Sewage Pumping System

### SECTION A-A

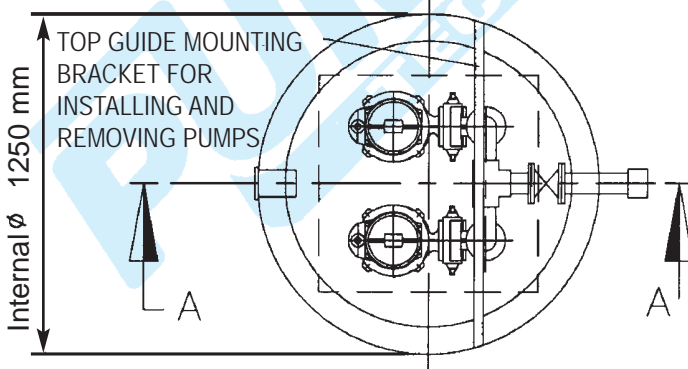
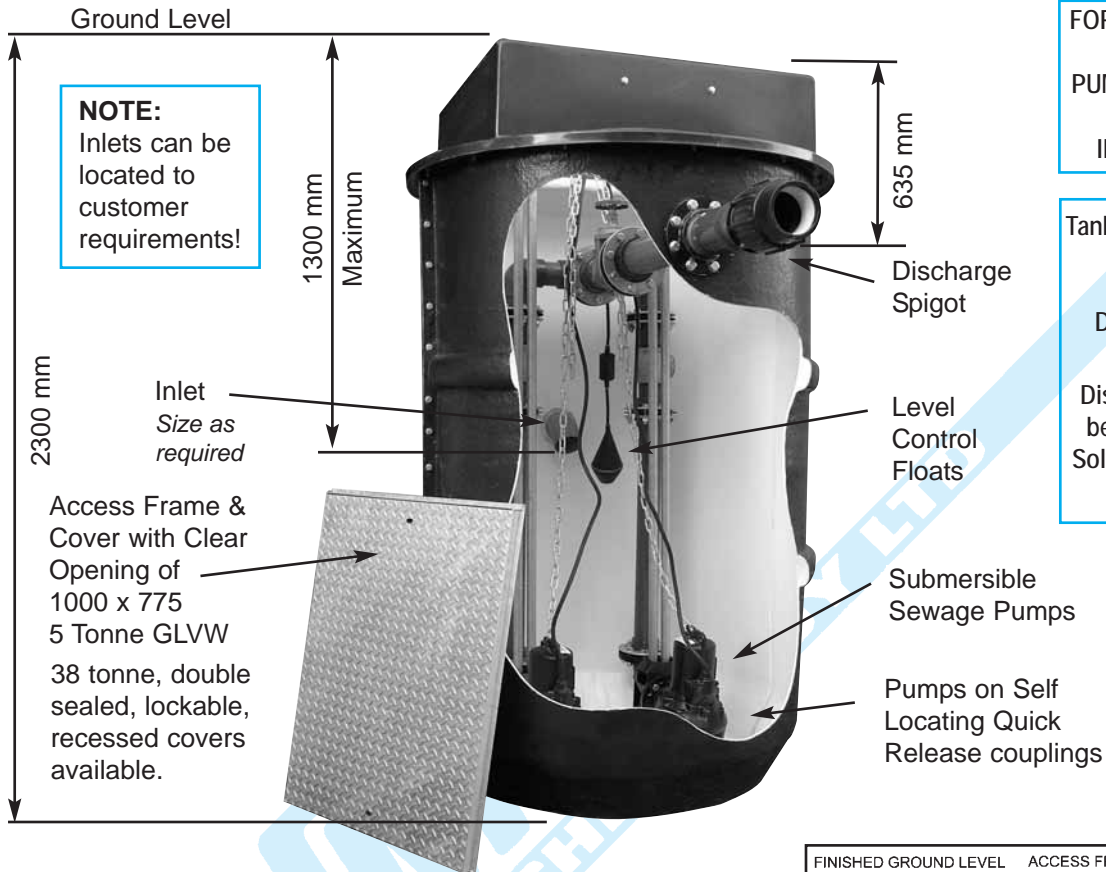

**SECTIONAL PLAN OF GRP TANK**

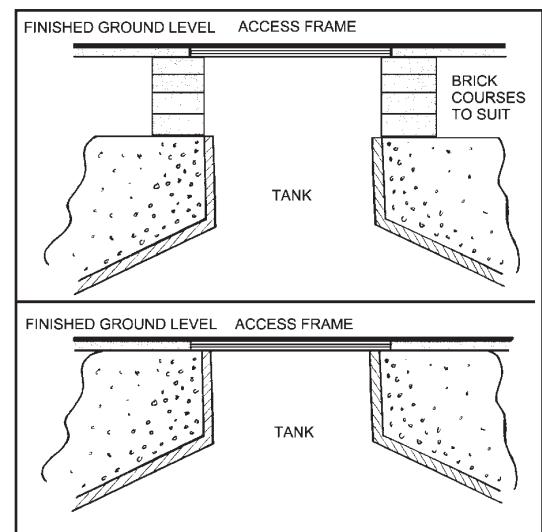

Due to a policy of continuous product improvement we reserve the right to alter specifications without notice.

**56 Youngs Industrial Estate, Aldermaston, Berks. RG7 4PW**  
**Tel: 01189 821555 Fax: 01189 821666**  
**E-mail: support@pumptechnology.co.uk**  
**Web Site: www.pumptechnology.co.uk**