

20RL - NON MERCURY LEVEL REGULATORS

Float Switches are inexpensive and efficient liquid level detectors, simple to install, designed for trouble free operation over a long life. The 20RL is a non-mercury tilt switch with micro-switch and rolling ball arrangement, which eliminates all heavy metals.

Construction

The unit comprises three major components :

1. The float chamber houses the microswitch arrangement, totally sealed within closed cell polyurethane foam, with a single pole double throw action. Outer walls of the switch are moulded in *Hypalon*, CSP Synthetic rubber.
2. The three-cored cable, connected to the microswitch assembly inside the float chamber, is sheathed in CPE synthetic rubber. This cable is supplied in three standard lengths, 5 metres, 10 metres and 20 metres $\pm 5\%$ of the length quoted. with other lengths available to order.
3. A stabilizing weight fixed to the cable approximately 120 mm from the float chamber is also coated in *Hypalon*.

Hypalon Du Pont de Nemours, Wilmington, Delaware.

Mounting

There are no hard and fast rules applicable to mounting these units, however the lead should be supported in an enclosed vessel, and in an open vessel it is advantageous to clip the lead to the side especially if excessive turbulence is experienced.

To obviate the effects of rapid switching conditions that would result if such turbulence is experienced, it is advantageous to use a maintaining circuit which both safeguards the microswitch and cuts out any chatter of the starters of associated pumps etc.

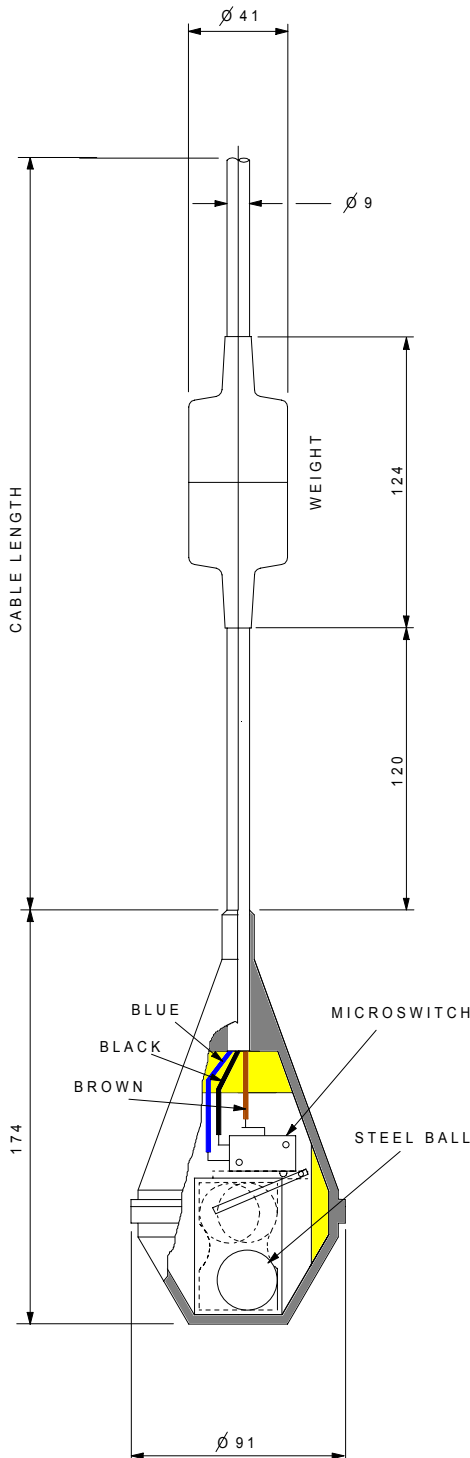

20RL - NON MERCURY FLOAT SWITCH

Method of Operation

The micro-switch assembly inside the float, axially mounted in line with the weight, changes contacts according to the float's position, as in the diagram below. Therefore as the liquid level drops or rises slowly, a pump or flow control suitably connected, can be switched in or out to maintain an average level of the liquid. By connecting only one side of the switch, the unit can be also used to fill or empty the tank as required.

Dimensions, in mm, do not take into consideration any lateral swing of the cable.

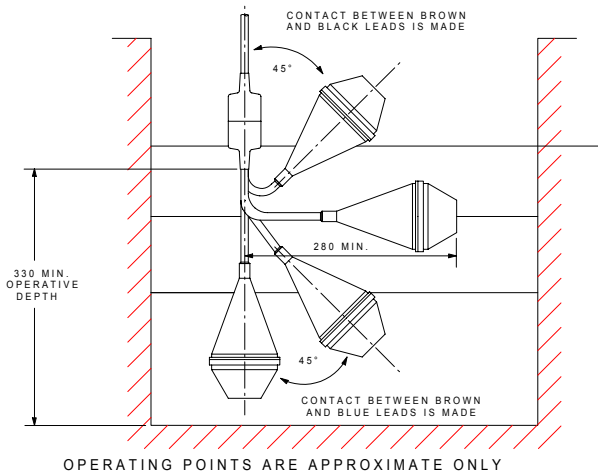

Connection diagram for automatically emptying tank

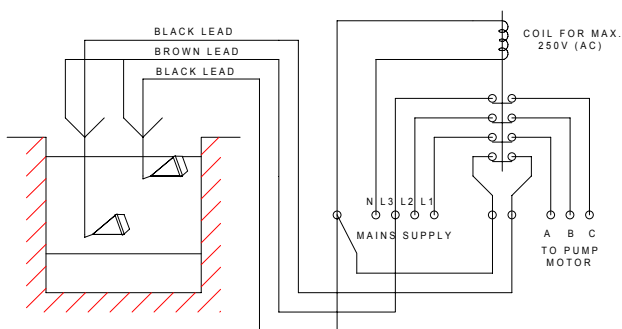

Connection diagram for automatically refilling tank

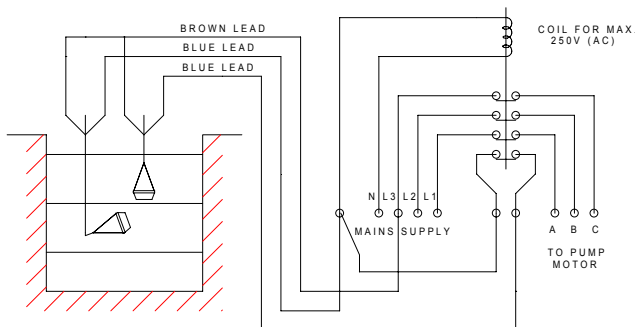

Contact rating: 250V 15A, non-inductive.
250V 10A, inductive. 1.3 HP

NOTE : Local regulations may limit the voltage.

Max. temperature 70° C

Max. submerged depth 20 metres

Compressive Strength 482 KN/m² (70 lbf/in²)

Operational in specific gravities from 0.8 to 1.3

Chemical Resistance

Against	Rating
Lubricants	Fair
Diesel oil & petrol	Poor
Vegetable & animal fats	Good
Water Absorption	Good
Oxidation	Good
Ozone	Good
Sunlight	Good
Dilute Acids	Good
Alkalis	Good
Alcohols	Good
Salt water	Good

A comprehensive list of chemical resistances is available on request.

When ordering please specify part numbers.

Type	Part Number	Weight (Approx.)
10 metre cable	20RL-L10M	1.8 Kg
20 metre cable	20RL-L20M	2.8 Kg