



The perfect solution for:

- Showers
- Dishwashers
- Sinks
- Glass washers
- Washing machines
- Combi ovens



DRAINMAJOR DUO

**Ideal for Offices, Schools, Shops, Pubs, Restaurants,
Factories, Hospitals and Warehouses.**

The Drainmajor Duo is a fully automatic waste water pumping system suitable for domestic and commercial installations where gravity drainage is not possible. This unit is designed to pump waste water from a Commercial/Industrial sink, wash basin, utility sink or any situation where waste water needs to be collected and pumped to the drainage system.

It has been **SPECIALLY** constructed to handle very hot water from a commercial dishwasher, washing machine and glass washer, unlike other waste water pumping systems which are unable to cope with such hot water.

Suitable for any commercial environment.

TECHNICAL SPECIFICATION

Model	PTL30(SL)	PTL60E	PTL60D	PTL730(H)E	PTL730D	PTL1030(H)E	PTL1030D
Power Supply	240v	240v	3ph	240v	3ph	240v	3ph
FLC (A)	1.4	3.3	1.23	3.9	1.4	6	2.4
Max Head (mtr)(Closed Valve)	7	9.5	9.5	10	10.5	13	13
Max Flow Rate (l/s)	1.7	4.3	4.3	5.0	6.0	7.9	7.9
Solids Handling (mm)	10	10	10	30	30	30	30
Minimum Invert Height (mm) floor to centre	110	130	130	155	155	185	185

* H Version suitable for 90° C water (Only available is 240v)

* SL Version suitable for 10% Saline Solution

INSTALLATION GUIDELINES

The Drainmajor Duo should be positioned on a firm level surface. The unit must be located lower than the outflow of the appliances served so as to provide a gravity fall into the unit.

It is extremely important to site the Drainmajor Duo with access in mind in the event of maintenance being required.

ON DELIVERY

Remove lid, check pump is correctly positioned and connecting pipework has not been damaged in transit.

INLET CONNECTIONS

Inlets can be positioned on the Drainmajor Duo to suit your site requirements. All inverts should be brought into the tank (using tank connectors) at the highest possible level from the floor. (See above technical info on minimum invert level)

Ensure that the inflow of water is not directed onto the float mechanism.

DIMENSIONS

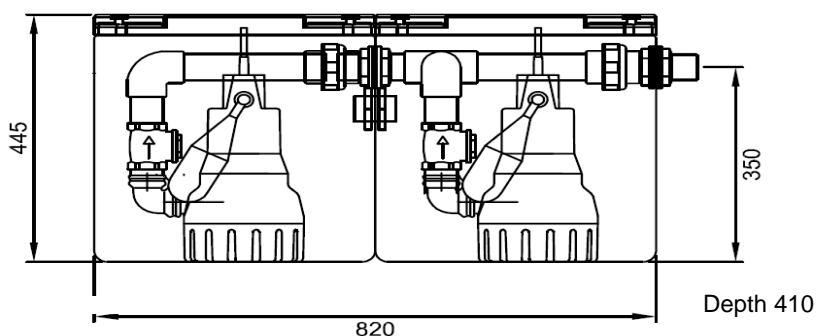

NOTE: no connections to be put through the lid as this inhibits easy removal of the lid for cleaning tank. (Note: tank MUST be positioned in such a way that lid can be removed easily to allow access to tank interior and pump cleaning)

DISCHARGE CONNECTION

The tank has a 1.1/2" BSP male thread discharge outlet. Two brass non return valves supplied in the vertical position fitted inside the tank off the pumps discharge. All pipework must be run in UPVC solvent weld.

IMPORTANT: Any bends in the rising main must be slow radius swept 90's.

If the discharge pipework connects to a soil stack, manhole, etc. below the discharge outlet of the tank, an anti syphon valve must be fitted to the highest point of the discharge pipework.

ELECTRICAL CONNECTION

A qualified person in accordance with the Institute Of Electrical Engineers Regulations should connect the unit to the appropriate mains supply taking into account all the electrical information provided.

IMPORTANT: All pump systems must be used with an appropriate motor rated protection device. Venting

Units require venting. If vent to atmosphere cannot be achieved a 1.1/4" vent pipe must be run off the side of the tank to the ceiling void and connected to a Charcovent. (2" pipe for Microvent, hot water)

MAINTENANCE

Depending on the environment it is recommend that the unit be cleaned every 4 weeks. It is recommended that the unit be rinsed through with warm water and any fat or grease deposits be removed for the tank.

(Commercial environments should be installed with a Greasetrap, please see our range)

Service should be done on a 6 to 12 month basis.

Please contact our sales office for a service and maintenance contract.

