

## MINIMATIC SEWAGE PUMP STATION



### **Pump:**

Cast iron/stainless steel construction.  
50mm (2") solids handling capacity  
Coolant filled motor.  
Mechanical seal.  
10 Meter cable.  
Max 6 Meter lift.  
Max flow 5 L/sec  
Float switch as standard

### **Tank:**

Polyethylene tank. 160L capacity.  
Screw down lid (Pedestrian rated)  
1 x 110mm/160mm inlet seal  
to allow inlet to be drilled on site.  
40mm cable duct.  
2" internal pipe work - 2" non-return valve  
2" quick release coupling - 2" cable duct  
Special audible/visual high level control box.

The *PTL Minimatic Sewage Pump Station* is suitable for domestic sewage pumping installations where gravity flow is not available. It can also be used for a variety of drainage applications.

It is ideal for extensions, garden rooms and similar small applications and is designed for fast, easy installation.

This unit is particularly suitable when water or sewage is collected at a lower level than the main sewer or a septic tank system and requires pumping uphill into these.

The *PTL Minimatic Sewage Pump Station* features a high spec. submersible pump with 50mm solid handling for optimum efficiency and peace of mind.

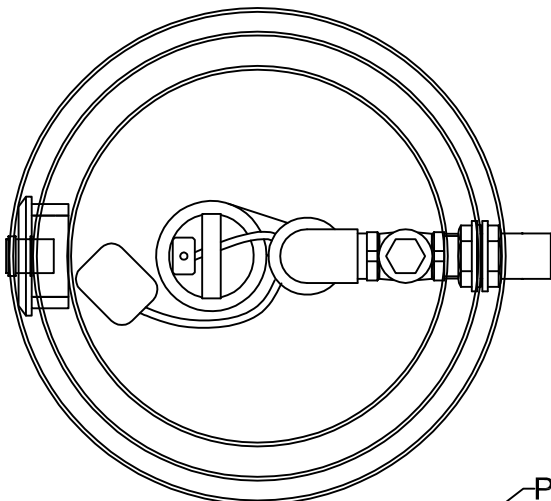

Pump Discharge.  
2 inch UPVC Spigot.

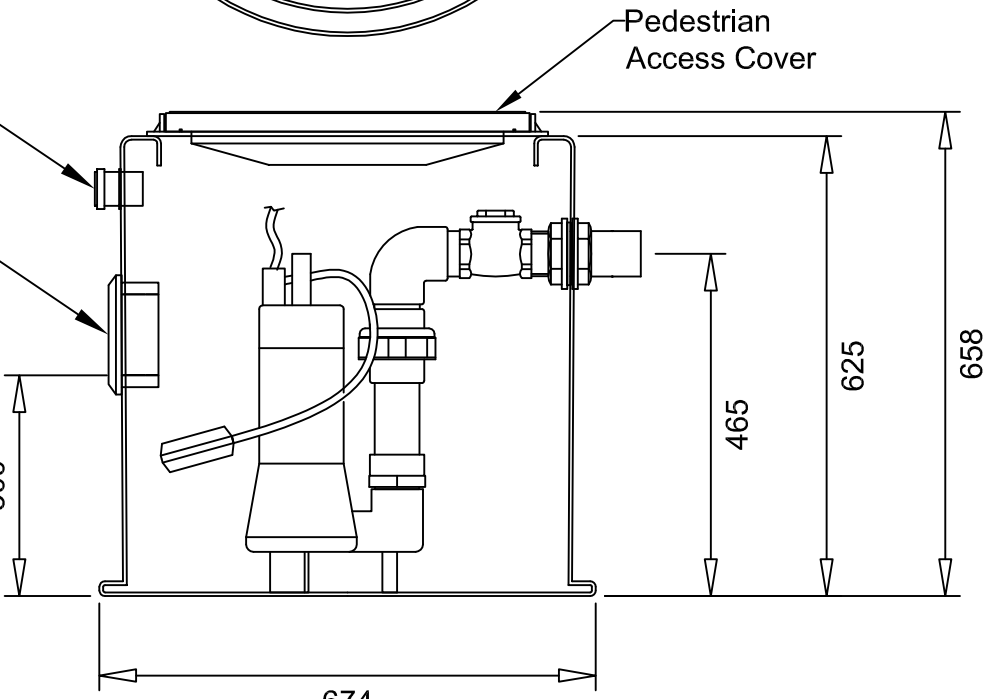

40mm Cable Duct.  
Supplied loose to be  
fitted on site.

110mm Inlet Grommet.  
Supplied loose to be  
fitted on site.

Recommended  
minimum.

300

465

625

658

674

ALL DIMENSIONS APPROXIMATE

This drawing is copyright and may not be reproduced without the permission of Pumptechnology Ltd. We reserve the right to change specification without prior notice.	Drawn by RJH	Checked by XXX	Approved by - date XX-00/00/00	Date 16/08/18	Scale Do Not Scale
				000	1/1