

EFFLU MAXI[®] 80 TWIN / COMPLI 1000/1000 HL

SEWAGE LIFTING STATIONS

- NEW: With modern HighLogo microprocessor control unit
- Ready to connect
- Submersible
- Duplex swing-type check valve
- Versatile connection facilities
- PE-tank 117 l
- Vortex impeller
- Smart Home capable



DESCRIPTION

With their performance graduations, the compli 1000 and compli 1000 HL disposal units have been designed for use in detached houses, in several residential units or in commercial buildings. During the design work, special attention was given to easy handling, space-saving erection and uncomplicated installation.

The submersible unit is permitted for general use in areas subject to flooding. The control unit has to be fitted in a well ventilated flood-proof room.

The PE tank has freely accessible drains, a cleaning opening at the top and a clamp-type inlet flange for an installation.

For the connection of a DN 100 feeding pipe a reducer DN 150/100 is enclosed. The tank has vertical inlet in DN 150 or DN 100. If not in use, the rear inlet must be closed with the plug set DN 150 (accessory).

The vortex impeller of the pump with a 70 mm free passage offers the safety you can rely on. Duplex systems have two pump units on one tank which are switched alternately or, if required, they are operated both in order to cope with peak load or reserve operation.

The compli lifting stations are available with modern microprocessor control unit (HighLogo). Via the large graphic display in conjunction with the multifunctional button the control system can be configured intuitively and flexibly. With optional accessories (GSM modem), SMS or e-mail transmission is also possible in the event of a malfunction.

The compli sewage lifting station can be integrated into a smart infrastructure. The FTJP radio transmitter is connected to the potential-free contact of the lifting station. It is now possible to transmit the switching status (e. g. an alarm message) to an EnOcean-capable smart home gateway (Wibutler, Afriso, Homee).

PERFORMANCE

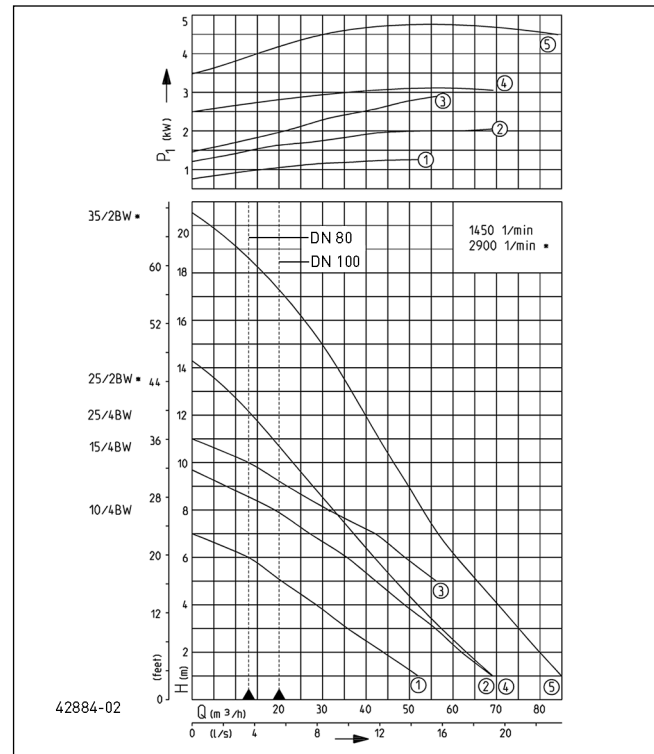

Type	Delivery head H [m]	1	2	3	4	5	6	7	8	9	10	11	13	15	17
compli 1010/4 BWE/BW	Flow rate Q [m³/h]	52	44	37	29	22	13								
compli 1015/4 BW		69	62	56	49	42	36	27	19						
compli 1025/4 BW						56	49	42	32	22	13				
compli 1025/2 BW		69	64	58	52	47	42	37	33	28	23	20	8		
compli 1035/2 BW		85	80	75	71	66	62	57	54	50	47	44	36	30	21

We reserve the right to change specifications without notice. Pump performance is subject to ISO 9906 tolerances

The minimum flow velocity in the pressure piping must be 0.7 m/s according to EN 12056. This data is represented in the performance curve as a limit of application.



EFFLU MAXI[®] 80 TWIN / COMPLI 1000/1000 HL

SEWAGE LIFTING STATIONS



SCOPE OF SUPPLY

Ready for plug in sewage lifting unit according to EN 12050-1 with clamp flange DN 150, reducer DN 150/100, two built-on subm. sewage pumps and connection flange DN 80 with pipe socket Ø 110 mm, reducer ring Ø 110 up to Ø 90, elastic connection c/w hose clamps, PVC collar DN 70 for ventilation connection, pre-mounted duplex swing-type check valve and autom. level controller, control unit (IP 44) c/w motor protection, motor contactor, transformer, mains-dependent alarm unit and

potential noc-contact for collective failure messages, with optical display of sense of rotation (only in case of three-phase current), alarm and operation, and 2 x manual-0-automatic switch. With Highlogo version even more functionalities such as operating hours counter and maintenance interval display.

Cable between tank and control 4 m, cable between control and plug 1.5 m.

MECHANICAL DATA

Pump	Vertical single-stage	Motor housing	Grey cast iron
Free passage	70 mm	Pump housing	Grey cast iron
Pressure pipe	DN 100	Submersible	Yes
Bearing	Ball bearings, grease-lubricated	Pressure outlet	DN 80
Impeller	Vortex impeller, grey cast iron	Tank capacity	117 l

ELECTRICAL DATA

Power line	4m H07RN-F	Insulation class	F
Type of enclosure	IP 68	Winding thermostat	Yes

COMPLI 1000/1000 HL

Type	Code No.	Voltage	Motor rating		Current	Wires	Plug	Oil chamber	Weight
			P1	P2					
compli 1010/4 BWE	JP50099	1/N/PE~230 V	1.55 kW	1.1 kW	7.1 A	4G1,5	Safety	No	103 kg
compli 1010/4 BW	JP50100	3/N/PE~400 V	1.30 kW	1.0 kW	2.8 A	6G1,5	CEE-16A	No	116 kg
compli 1015/4 BW	JP50101	3/N/PE~400 V	2.20 kW	1.7 kW	3.9 A	6G1,5	CEE-16A	No	117 kg
compli 1025/4 BW	JP50102	3/N/PE~400 V	3.00 kW	2.2 kW	5.1 A	6G1,5	CEE-16A	No	124 kg
compli 1025/2 BW	JP50103	3/N/PE~400 V	3.30 kW	2.6 kW	5.4 A	6G1,5	CEE-16A	Yes	124 kg
compli 1035/2 BW	JP50104	3/N/PE~400 V	4.80 kW	4.0 kW	8.2 A	6G1,5	CEE-32A	Yes	139 kg
compli 1010/4 BWE HL	JP50105	1/N/PE~230 V	1.55 kW	1.1 kW	7.1 A	4G1,5	Safety	No	103 kg
compli 1010/4 BW HL	JP50106	3/N/PE~400 V	1.30 kW	1.0 kW	2.8 A	6G1,5	CEE-16A	No	116 kg
compli 1015/4 BW HL	JP50107	3/N/PE~400 V	2.20 kW	1.7 kW	3.9 A	6G1,5	CEE-16A	No	117 kg
compli 1025/4 BW HL	JP50108	3/N/PE~400 V	3.00 kW	2.2 kW	5.1 A	6G1,5	CEE-16A	No	124 kg
compli 1025/2 BW HL	JP50109	3/N/PE~400 V	3.30 kW	2.6 kW	5.4 A	6G1,5	CEE-16A	Yes	124 kg
compli 1035/2 BW HL	JP50110	3/N/PE~400 V	4.80 kW	4.0 kW	8.2 A	6G1,5	CEE-32A	Yes	139 kg

EFFLU MAXI[®] 80 TWIN / COMPLI 1000/1000 HL SEWAGE LIFTING STATIONS

Dimensions compli 1000 (mm)

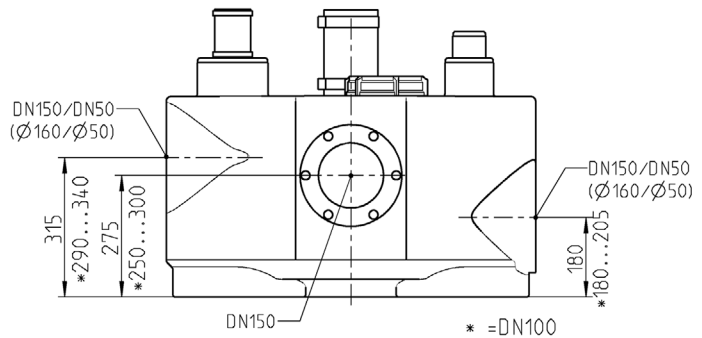
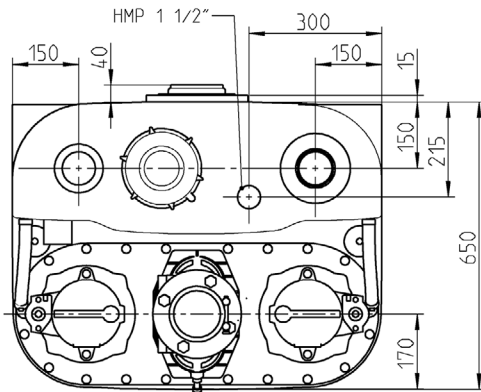
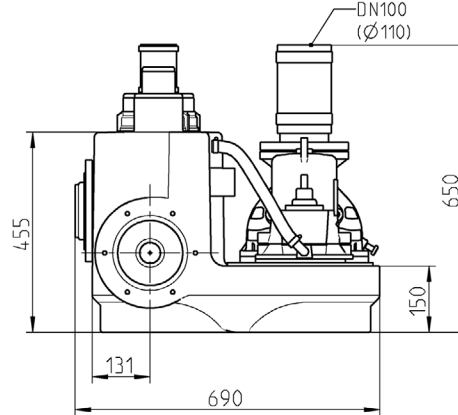
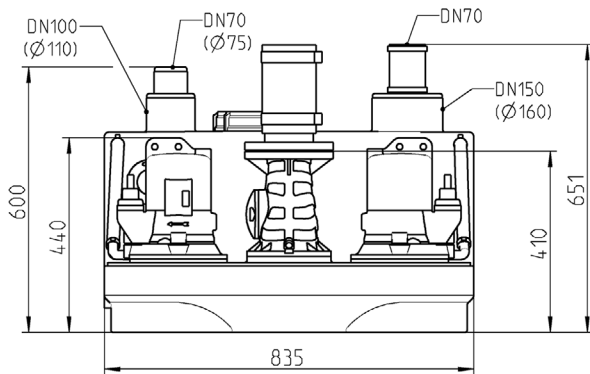

55011-00

Example of installation

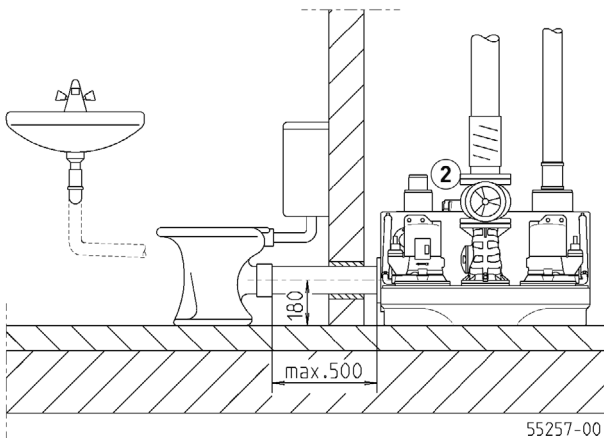

55257-00

Example of installation

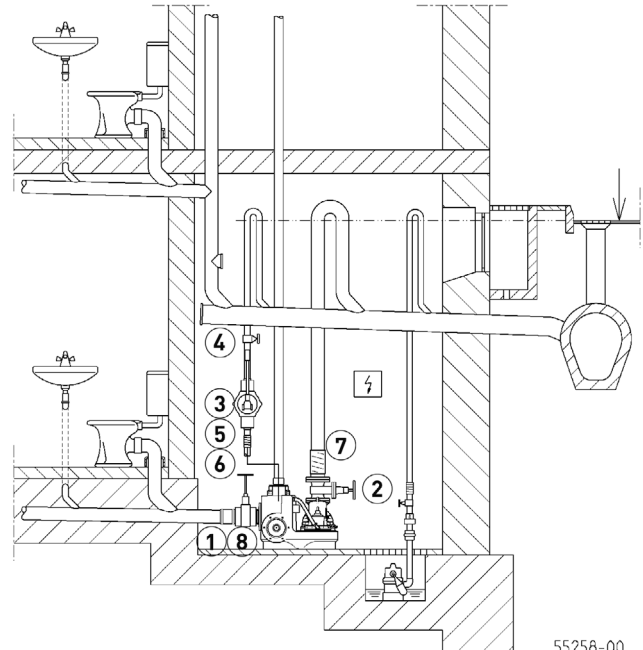

55258-00

EFFLU MAXI[®] 80 TWIN / COMPLI 1000/1000 HL





SEWAGE LIFTING STATIONS



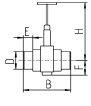
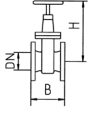
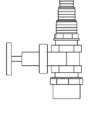

All types have DN 80 / PN 10 connecting flange, however with pipe socket DN 100. For this reason, a non-return valve for the pressure pipe need to be chosen for DN 80 only in case of direct erection. The ownstream pressure pipe is connected to DN 100 by an elastic connection. Sewage lifting stations are to be used for the transport of faecal matter and domestic wastewater in building drainage systems as described in German standard DIN 1986 T3. In keeping with the stipulations of German / European standard EN 12056-4 they

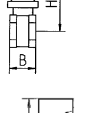
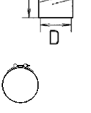
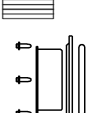
have to be mounted with collecting tanks inside building permitting a free space of 60 cm for operation and repair. The pressure pipe has to be passed above the locally defined backpressure level and a non-return valve tested in keeping with German / European standard 12050-4 has to be mounted. In keeping with German / European standard 12056 the ventilation pipe has to be passed up to the roof. EN 12056 paragraph 5.1 In applications where the waste-water inlet must not be interrupted a double system has to be installed.

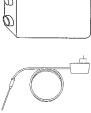
MECHANICAL ACCESSORY

				Code No.
	① Inlet gate valve PVC	with two pipe sockets, DN 100, PN1	360x295 (HxW)	JP28297
		with two pipe sockets, DN 150, PN2.5	660x450 (HxW)	JP28591
	② Sluice valve	DN 80, PN 10, EN 1171	315x180 (HxB)	JP00639
	③ Connection for emergency de-watering	with stop valve and hose connection 1", 1 1/4" and 1 1/2"		JP49138
	Hand diaphragm pump	for emergency purposes (up to H geod 15 m)	640x1 1/2" (HxD)	JP00255
	④ Stop valve	brass, 1/2" (DN 40), PN 16	125x60 (HxB)	JP44786
	⑤ Elastic connection	1/2" (DN 40), PN 4	120x50 (HxD)	JP44777
	⑥ Hose band clamp	1/2"		JP44763
	⑦ Adapter ring	DN 100-DN 80 SML		JP50174
	⑧ Opening set	DN 150, required for lateral connection		JP43156

ELECTRICAL ACCESSORY

			Code No.
	a Rechargeable battery	for mains independent alarm	JP44850
	b Seal leak detector	DKG	JP44900
	c Smart Home	FTJP radio transmitter	JP47209