

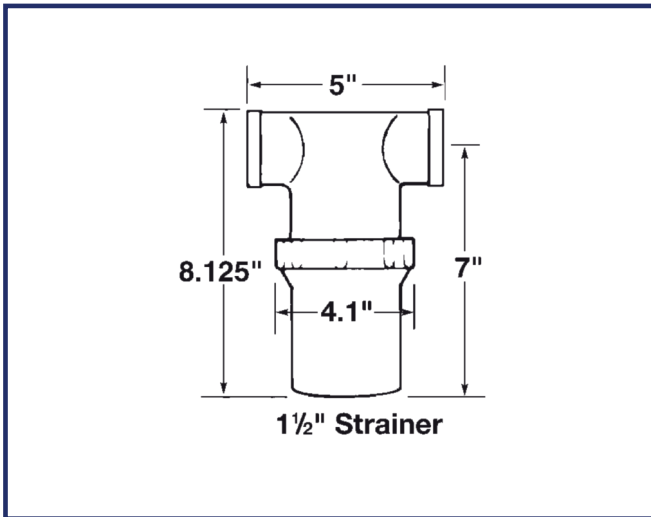

In-Line Strainer Part No 900

General Description:

Suitable for DrainMaster, DrainMajor, DrainMajor Duo, DrainKing and Hebefix pumping systems. Ideal for hairdressers, vets, pet grooming and cleaners sinks. (Not suitable for kitchen sinks with grease)



Specification:

Strainer has 1 1/2" BSP female threaded connections to which are fitted plastic male adaptors for solvent weld 1 1/2" plastic waste pipe. Filter screens are 20 mesh stainless steel which are easily removable for cleaning.

Installation:

Install the in-line strainer on the inlet side of the pumping system. The arrow moulded in the strainer cap indicates flow of liquid.

Pump Technology Ltd. - 0118 9821 555 - www.pumptechnology.co.uk

Official Distributor and Stockist Authorised by Jung Pumpen GmbH



1 of 1

Pump Technology Ltd. reserves the right to change the specification without prior notice.