

DRAINING 60 TWIN (3ph) (Duty/Standby Wastewater Pumping System with Control Panel)



DrainKing 60 Twin (3ph) Part No. 172/NS
(Duty/Standby Wastewater Pumping System with
Control Panel)

General Description:

DrainKing 60 Twin (3ph) features a heavy-duty tank and submersible pump for automatically pumping wastewater from commercial kitchens, multiple sinks, dishwashers etc.

The DrainKing Twin provides users with the additional security of duty/standby operation. If one pump should become blocked or fail, the wastewater would rise within the common tank, and activate the high-level alarm. The control panel would start the other pump as the standby pump.



Control Panel:

The DrainKing Twin is supplied with a pump station control panel and a single high-level finger float. The duty pump is automatically alternated after every pump operation. If the high-level alarm is activated the standby pump would become operational. The panel features door isolation switch, pump 1 or 2 operational/tripped lights, alarm buzzer (minimum volume of 80 Dba at 1m distance) alarm on/off switch, 3 off volt free ports for BMS connection.

A rechargeable battery is fitted in case of mains electricity supply failure.

DRAINING 60 TWIN (3ph) (Duty/Standby Wastewater Pumping System with Control Panel)

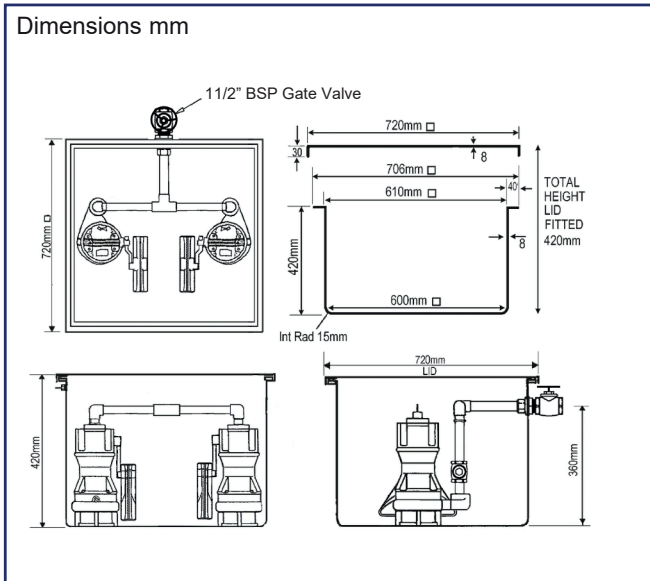

Tank:

Manufactured from GRP and fully rigged with internal pipe work, gate valve and non-return valves.

Tank Volume: 151.2 litres

Total Approximate Usable Volume - 100.8 litres

Tank Inlets:

To suit site layout, all inverts should be brought into the side of the tank by drilling a hole and using an appropriate tank connector. Minimum invert height 120 mm.

Tank Outlet:

Fitted 1 1/2" BSP male thread discharge outlet (Gate Valve supplied female thread)

Tank Venting:

To suit site layout, a vent should be taken from the side of the tank by drilling a hole and using an appropriate tank connector. Vent pipe should be 1 1/4" min. to air or via a Pump Technology MicroVent.

Pump:

- Safe to run dry
- 20 mm free passage with EIP technology
- Cooling jacket for motor housing
- SiC mechanical seal independent of sense of rotation
- Replaceable moisture sealed cable inlet
- Flushing device
- Fluid temperature 35°C, temporarily 60°C (10 mins)



Description:

The heavy duty centrifugal submersible drainage pump U6K DS is suitable for dealing with wastewater and capable of handling soft solids up to 20mm in particle size.

Dimensions/switching points U6K DS (mm)

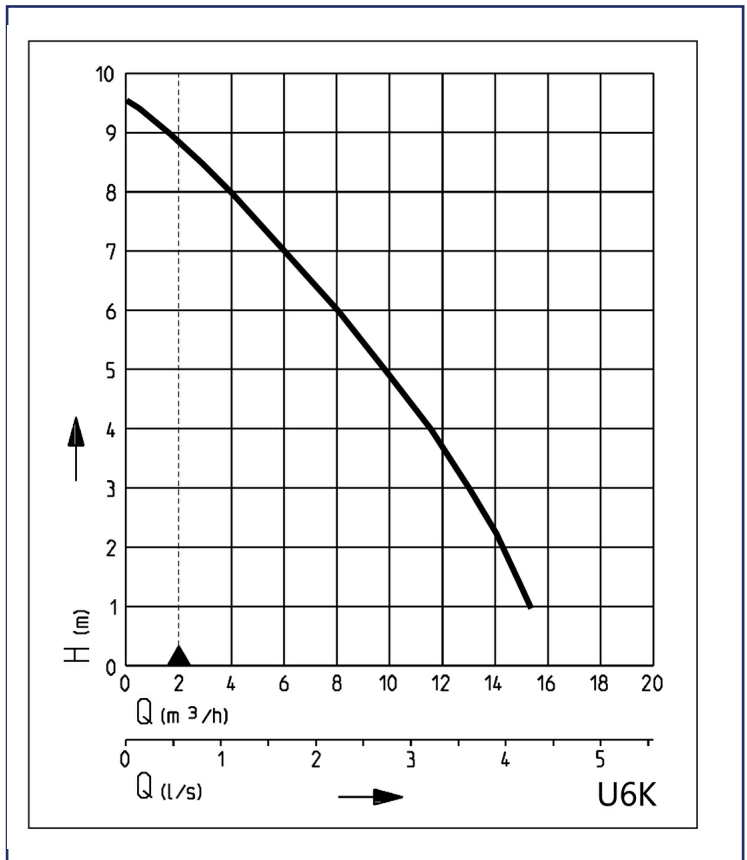
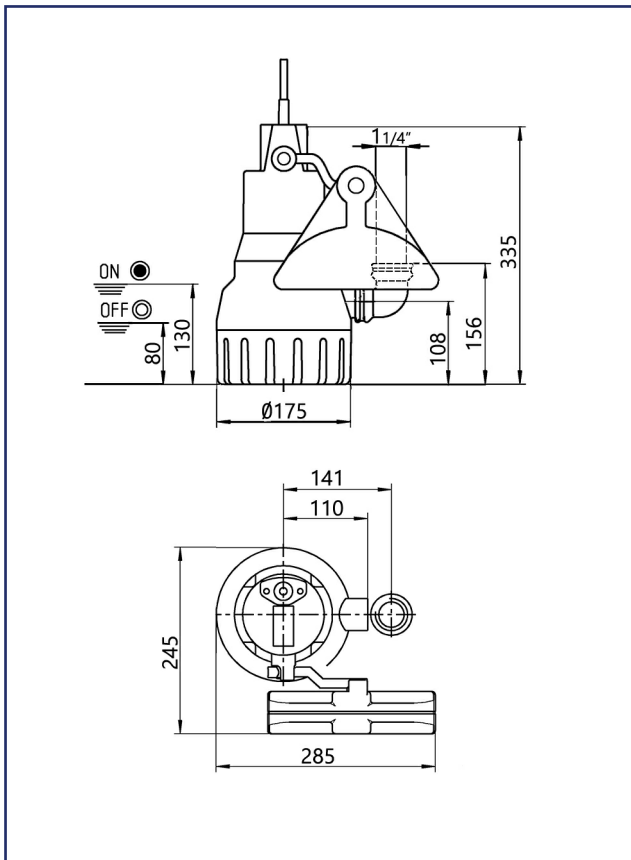

Scope of Supply

Pump ready for connection acc. to EN 12050 with 90°, 1¼" female connection elbow, 4m cable with automatic level float switch.

Mechanical Data

Pump	Vertical single stage	Run dry protection	Yes
Free passage	20 mm	Shaft	Stainless Steel
Bearing	Ball bearing, grease-lubricated	Impeller	Vortex impeller, GFK
Seal on motor side	Rotary shaft seal	Motor housing	Stainless Steel
Oil chamber	Yes	Submersible	Yes
Seal on medium side	SiC mechanical seal	Pressure outlet	1¼"

Electrical Data

Motor rating P1	0.75kW	Winding thermostat	Yes
Type of enclosure	IP 68	Motor protection	Integrated
Insulation Class	B		

U6K ES

Type	Code No.	Voltage	Motor rating P2	Current	Power line	Wires	Plug	Weight
With built-in level control								
U6K DS, 4m cable	JP00229	3/PE-400V	0.55kW	1.3A	4m H07RN-F	4G1,0	CEE	5.9kg

Notes:

- This unit is for wastewater only
- Ensure the location of the DrainKing enables the lid to be easily removed for regular inspection and maintenance
- If the discharge pipework connection to a soil stack, manhole etc. is below the discharge outlet of the tank, an anti-syphon unit must be fitted at the highest point of the discharge pipework
- Warranty: The DrainKing 60 Twin (3ph) comes complete with a one year warranty.

Pump Technology Ltd. - 0118 9821 555 - www.pumptechnology.co.uk

Official Distributor and Stockist Authorised by Jung Pumpen GmbH



4 of 4

Pump Technology Ltd. reserves the right to change the specification without prior notice.